

FIRST ALERT

SC5 Wired Smart Smoke & Carbon Monoxide Alarm

SMC0600NV-AC-A

Installation & Reference Manual

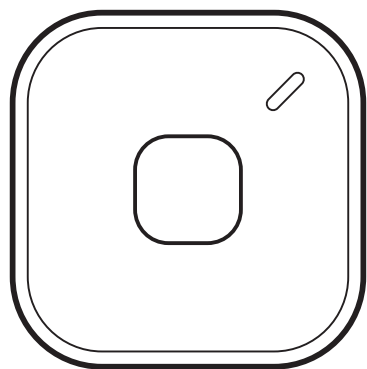

IMPORTANT! PLEASE READ CAREFULLY AND SAVE.

The warnings/limitations card and manual contains important information about your Smoke Alarm's operation. If you are installing this Alarm for use by others, you must leave this manual—or a copy of it—with the end user.

Para el manual del usuario en español, por favor visite firstalert.com

INSTALLATION

WHERE TO INSTALL THIS Alarm

Minimum coverage for Smoke Alarms, as recommended by the National Fire Protection Association (NFPA), is one Smoke Alarm on every floor, in every sleeping area, and in every bedroom (See "Regulatory Information For Smoke Alarms" for details on the NFPA recommendations).

For CO Alarms, the National Fire Protection Association (NFPA) recommends that a CO Alarm should be centrally located outside of each separate sleeping area in the immediate vicinity of the bedrooms. For added protection, install additional CO Alarms in each separate bedroom, and on every level of your home.

NOTE: For added protection, install an additional Smoke/CO Alarm at least 15 feet (4.6 meters) away from the furnace or fuel burning heat source where possible. In smaller homes or in manufactured homes where this distance cannot be maintained, install the Alarm as far away as possible from the furnace or other fuel burning source. Installing the Alarm closer than 15 feet (4.6 meters) will not harm the Alarm, but may increase the frequency of unwanted alarms.

! WARNING!

THIS PRODUCT IS INTENDED FOR USE IN ORDINARY INDOOR LOCATIONS OF FAMILY LIVING UNITS. IT IS NOT DESIGNED TO MEASURE COMPLIANCE WITH OCCUPATIONAL SAFETY AND HEALTH ADMINISTRATION (OSHA) COMMERCIAL OR INDUSTRIAL STANDARDS.

In general, install combination Smoke and Carbon Monoxide Alarms:

- On every level of your home, including finished attics and basements.
- Inside every bedroom, especially if people sleep with the door partly or completely closed.
- In the hall near every sleeping area. If your home has multiple sleeping areas, install a unit in each. If a hall is more than 40 feet (12 meters) long, install a unit at each end.
- At the top of first-to-second floor stairs and at the bottom of the basement stairs.
- For additional coverage, install Alarms in all rooms, halls, and storage areas, where temperatures normally remain between 40° F and 100° F (4.4° C and 37.8° C).
- When installing on the ceiling, place the Alarm as close to the center as possible.
- When installing on the wall, the top edge of Smoke Alarms should be placed between 4 inches (102 mm) and 12 inches (305 mm) from the wall/ceiling line.
- In either case, install at least 4 inches (102 mm) from where the wall and ceiling meet. See "Avoiding Dead Air Spaces" for more information.

NOTE: For any location, make sure no door or other obstruction could keep carbon monoxide or smoke from reaching the Alarm.

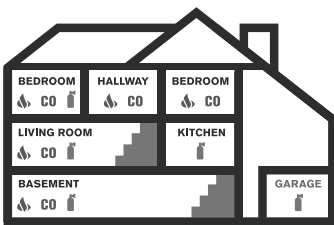

- Smoke Alarm**
One on every level and in every bedroom
- Carbon Monoxide Alarm**
One on every level and in every bedroom
- Fire Extinguisher**
One on every level, plus kitchen and garage

INTRODUCTION

Thank you for choosing First Alert® for your Smoke and Carbon Monoxide Alarm needs. You have purchased a state-of-the-art Smoke & Carbon Monoxide Alarm designed to help provide you with early warning (Heads-Up) of a smoke and/or carbon monoxide danger. Please take the time to read this manual and make the Smoke & Carbon Monoxide Alarm an integral part of your family's safety plan.

Alarm Features

- Voice Alerts with Heads-Up Warning: Friendly voice tells you what the danger is and its location.
- Hardwire Interconnect: When one alarm sounds, all compatible alarms sound.
- Quick Connect Plug: Allows for easy installation. No need to rewire.
- Mobile alerts whether home or away

Installation Notes

- This unit will not alert hearing impaired residents. It is recommended that you install special units which use devices like flashing strobe lights to alert hearing impaired residents.
- This unit must be powered by a 24-hour, 120VAC pure sine wave 60Hz circuit. Be sure the circuit cannot be turned off by a switch, dimmer, or ground fault circuit interrupter. Failure to connect this unit to a 24-hour circuit may prevent it from providing constant protection.
- Test this Smoke Alarm once a week. If the alarm ever fails to test correctly, have it replaced immediately! If the alarm is not working properly, it cannot alert you to a problem.
- Install in accordance with installation instructions, applicable codes and ordinances and in a manner acceptable to the authority having jurisdiction. Check with your local Fire Department for current requirements in your area.

Manufactured by
Resideo Technologies, Inc.
Scottsdale, AZ 85254
www.resideo.com

M08-0669-001 L2 7/24 Rev A

© 2024 Resideo Technologies, Inc. All Rights Reserved.
These products are manufactured by Resideo Technologies, Inc. and its affiliates.

WHERE NOT TO INSTALL THIS ALARM

FOR BEST PERFORMANCE, IT IS RECOMMENDED YOU AVOID INSTALLING SMOKE/CO ALARMS IN THESE AREAS:

- In garages, furnace rooms, crawl spaces and unfinished attics. Avoid extremely dusty, dirty or greasy areas.
- Where combustion particles are produced. Combustion particles form when something burns. Areas to avoid include poorly ventilated kitchens, garages, and furnace rooms. Keep units at least 10 feet (3 meters) from the sources of combustion particles (stove, furnace, water heater, space heater) if possible. In areas where a 20-foot (6 meter) distance is not possible – in modular, mobile, or smaller homes, for example – it is recommended the Smoke Alarm be placed as far from these fuel-burning sources as possible. The placement recommendations are intended to keep these Alarms at a reasonable distance from a fuel-burning source, and thus reduce "unwanted" Alarms. Unwanted Alarms can occur if a Smoke Alarm is placed directly next to a fuel-burning source. Ventilate these areas as much as possible.
- Within 5 feet (1.5 meters) of any cooking appliance. In air streams near kitchens. Air currents can draw cooking smoke into the smoke sensor and cause unwanted Alarms.
- In extremely humid areas. This Alarm should be at least 10 feet (3 meters) from a shower, sauna, humidifier, vaporizer, dishwasher, laundry room, utility room, or other source of high humidity.
- In direct sunlight.
- In turbulent air, like near ceiling fans or open windows. Blowing air may prevent smoke from reaching the sensors.
- In areas where temperature is colder than 40° F (4.4° C) or hotter than 100° F (37.8° C). These areas include non air-conditioned crawl spaces, unfinished attics, uninsulated or poorly insulated ceilings, porches, and garages.
- In insect infested areas. Insects can clog the openings to the sensing chamber.
- Less than 12 inches (305 mm) away from fluorescent lights. Electrical "noise" can interfere with the sensor.
- In "dead air" spaces.

AVOIDING DEAD AIR SPACES

"Dead air" spaces may prevent smoke from reaching the Smoke Alarm. To avoid dead air spaces, follow installation recommendations below. On ceilings, install Smoke Alarms as close to the center of the ceiling as possible. If this is not possible, install the Smoke Alarm at least 4 inches (102 mm) from the wall or corner. For wall mounting (if allowed by building codes), the top edge of Smoke Alarms should be placed between 4 inches (102 mm) and 12 inches (305 mm) from the wall/ceiling line, below typical "dead air" spaces. On a peaked, gabled, or cathedral ceiling, install the first Smoke Alarm within 3 feet (0.9 meters) of the peak of the ceiling, measured horizontally. Additional Smoke Alarms may be required depending on the length, angle, etc. of the ceiling's slope. Refer to NFPA 72 for details on requirements for sloped or peaked ceilings.

BASIC SAFETY INFORMATION

IMPORTANT!

- Dangers, Warnings, and Cautions alert you to important operating instructions or to potentially hazardous situations. Pay special attention to these items.
- This smoke and co alarm is approved for use in single-family residences. It is NOT designed for marine or RV use.
- This Alarm must have battery power to operate.
- This Smoke Alarm cannot operate without working batteries. Removing the batteries for any reason, or failing to replace the batteries at the end of their service life, removes your protection.
- The Smoke Alarm will only indicate the presence of smoke that reaches the sensor.
- The Smoke Alarm is not designed to sense gas, heat or flames.

! WARNING!

- Installation of this unit must conform to the electrical codes in your area; Articles 210 and 300.3 (B) of NFPA 70 (NEC), NFPA 72, NFPA 101; SBC (SBCCI); UBC (ICBO); NBC (BOCA); OTFDC (CABO), and any other local or building codes that may apply. Wiring and installation must be performed by a licensed electrician. Failure to follow these guidelines may result in injury or property damage.
- NEVER ignore any alarm. See "If Your Smoke Alarm Sounds" for more information on how to respond to an alarm. Failure to respond can result in injury or death.
- The Silence Features are for your convenience only and will not correct a problem. See "Using the Silence Features" for details. Always check your home for a potential problem after any alarm. Failure to do so can result in injury or death.
- Never disconnect the power from an AC powered unit to stop an unwanted alarm. Doing so will disable the unit and remove your protection. In the case of a true unwanted alarm open a window or fan the smoke away from the unit.
- The alarm will reset automatically when it returns to normal operation. Never remove the batteries from a battery operated unit to stop an unwanted alarm (caused by cooking smoke, etc.). Instead open a window or fan the smoke away from the unit. The alarm will reset automatically.

! CAUTION!

- Connect this unit ONLY to other compatible units. See "How To Install This Smoke Alarm" for details. Do not connect it to any other type of alarm or auxiliary device.
- Connecting anything else to this unit may damage it or prevent it from operating properly.
- Do not stand too close to the unit when the alarm is sounding. It is loud to wake you in an emergency. Exposure to the horn at close range may harm your hearing.
- Do not paint over the unit. Paint may clog the openings to the sensing chambers and prevent the unit from operating properly.
- Be aware of various situations against which the smoke alarm may not be effective, for example:
 1. Fires where the victim is intimate with a flaming initiated fire; for example, when a person's clothes catch fire while cooking;
 2. Fires where the smoke is prevented from reaching the smoke alarm due to a closed door or other obstruction;
 3. Incendiary fires where the fire grows so rapidly that an occupant's egress is blocked even with properly located smoke alarms.

HOW TO INSTALL THIS ALARM

IMPORTANT!

This Smoke/CO Alarm is designed to be mounted on any standard wiring junction box up to a 4-inch (10 cm) size, on either the ceiling or wall (if allowed by local codes). Read "Where to Install This Alarm" and "Where This Alarm Should Not Be Installed" before you begin installation.

Tools you will need: needle-nose pliers or utility knife, standard flathead screwdriver, wire strippers.

! WARNING!

Make sure the Alarm is not receiving excessively noisy power. Examples of noisy power could be major appliances on the same circuit, power from a generator or solar power, light dimmer on the same circuit or mounted near fluorescent lighting. Excessively noisy power may cause damage to your Alarm.

THE PARTS OF THIS ALARM

The Mounting Bracket: The mounting bracket installs onto the junction box. It has a variety of screw slots to fit most boxes.

The Power Connector: The power connector plugs into a power input block on the Alarm. It supplies the unit with AC power.

- The black wire is "hot."
- The white wire is neutral.
- The orange wire is used for interconnect.

If you need to remove the power connector, turn POWER OFF first. Insert a flat screwdriver blade between the power connector and the security tab inside the power input block. Gently pry back the tab and pull the connector free.

THE PARTS OF THIS SMOKE/CO ALARM

1. Mounting Bracket
2. Mounting Slots
3. Hot (Black) AC Wire
4. Neutral (White) AC Wire
5. Interconnect (Orange) Wire
6. Quick-Connect Power Connector
7. Turn this way to remove from bracket
8. Turn this way to attach to bracket
9. Battery Compartment Door

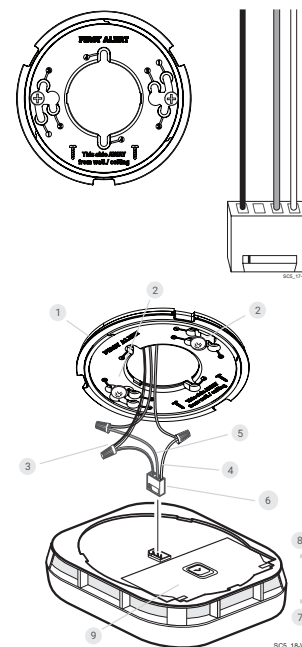

ABOUT SMOKE ALARMS

Types of Alarms

All these Smoke Alarms are designed to provide early warnings of fires if located, installed and cared for as described in the user's manual, and if smoke reaches the Alarm. If you are unsure which type of Smoke Alarm to install, refer the National Fire Protection Association (NFPA) Standard 72 (National Fire Alarm and Signaling Code) and NFPA 101 (Life Safety Code). National Fire Protection Association, One Batterymarch Park, Quincy, MA 02269-9101. Local building codes may also require specific units in new construction or in different areas of the home.

Battery (DC) operated Smoke Alarms: Provide protection even when electricity fails, provided the batteries are fresh and correctly installed. Units are easy to install, and do not require professional installation. However, they do not provide interconnected functionality.

AC powered Smoke Alarms: Can be interconnected so if one unit senses smoke, all units Alarm. They do not operate if electricity fails. **AC with battery (DC) back-up:** will operate if electricity fails, provided the batteries are fresh and correctly installed. AC and AC/DC units must be installed by a qualified electrician.

Smoke Alarms for solar or wind energy users and battery backup power systems: AC powered Smoke Alarms should only be operated with true or pure sine wave inverters. Operating this Alarm with most battery-powered UPS (uninterrupted power supply) products or square wave or "quasi sine wave" inverters will damage the Alarm. If you are not sure about your inverter or UPS type, please consult with the manufacturer to verify.

Smoke Alarms for the hearing impaired: Special purpose Smoke Alarms should be installed for the hearing impaired. They include a visual Alarm and an audible Alarm horn, and meet the requirements of the Americans With Disabilities Act. Can be interconnected so if one unit senses smoke, all units Alarm.

Smoke Alarms are not to be used with detector guards unless the combination has been evaluated and found suitable for that purpose.

All First Alert® Smoke Alarms conform to regulatory requirements, including UL217 and are designed to detect particles of combustion. Smoke particles of varying number and size are produced in all fires.



Ionization technology is generally more sensitive than photoelectric technology at detecting small particles, which tend to be produced in greater amounts by flaming fires, which consume combustible materials rapidly and spread quickly. Sources of these fires may include paper burning in a wastebasket, or a grease fire in the kitchen.



Photoelectric technology is generally more sensitive than ionization technology at detecting large particles, which tend to be produced in greater amounts by smoldering fires, which may smolder for hours before bursting into flame. Sources of these fires may include cigarettes burning in couches or bedding.

For maximum protection, use both types of Smoke Alarms on each level and in every bedroom of your home.

FIRE SAFETY TIPS

Follow safety rules and prevent hazardous situations:

1. Use smoking materials properly. Never smoke in bed.
2. Keep matches or lighters away from children;
3. Store flammable materials in proper containers;
4. Keep electrical appliances in good condition and don't overload electrical circuits;
5. Keep stoves, barbecue grills, fireplaces and chimneys grease- and debris-free;
6. Never leave anything cooking on the stove unattended;
7. Keep portable heaters and open flames, like candles, away from flammable materials;
8. Don't let rubbish accumulate. Keep Alarms clean, and test them weekly. Replace Alarms immediately if they are not working properly. Smoke Alarms that do not work cannot alert you to a fire. Keep at least one working fire extinguisher on every level, and an additional one in the kitchen. Have fire escape ladders or other reliable means of escape from an upper level in case stairs are blocked;
9. Have an escape plan and practice it regularly.

FOLLOW THESE SIMPLE STEPS

The basic installation of this Smoke/CO Alarm is similar whether you want to install one Alarm, or interconnect more than one Alarm.

1. Make the wiring connections (below).

NOTE: TURN POWER OFF AT THE BREAKER BOX BEFORE MAKING CONNECTIONS BELOW.

STAND-ALONE ALARM ONLY:

- Connect the white wire on the power connector to the neutral wire in the junction box.
- Connect the black wire on the power connector to the hot wire in the junction box.
- Tuck the orange wire inside the junction box. It is used for interconnect only.

INTERCONNECTED UNITS ONLY:

- Strip off about 1/2" (12 mm) of the plastic coating on the orange wire on the power connector.
- Connect the white wire on the power connector to the neutral wire in the junction box.
- Connect the black wire on the power connector to the hot wire in the junction box.
- Connect the orange wire on the power connector to the interconnect wire in the junction box.
- Repeat for each unit you are interconnecting. Never connect the hot or neutral wires in the junction box to the orange interconnect wire.

2. Check all connections.
3. Feed the wire connector through the hole in the mounting bracket and attach the mounting bracket to the mounting surface. **NOTE:** Do not overtighten screws!
4. Insert the wiring harness connector to the receptacle on the device.
5. If not done so already, activate the battery back-up by removing the battery tab.
6. Position the base of the Alarm over the mounting bracket, and turn the Alarm clockwise (right) until the unit is in place. If wall mounted, adjust unit so words are level.
7. Turn AC power back on. Under normal operation, the Green power indicator light will shine continuously.

STAND-ALONE ALARM ONLY:

- If you are only installing one Alarm, restore power to the junction box.

INTERCONNECTED UNITS ONLY:

- If interconnecting multiple Alarms, repeat steps 1-6 for each Alarm in the series. When finished, restore power to the junction box.

8. If the Green power indicator light does not light, TURN OFF POWER TO THE JUNCTION BOX and recheck all connections. If all connections are correct and the Green power indicator still does not light when you restore the power, the device should be replaced immediately.
9. Test each Alarm. Press and hold the Test/Silence button until the unit Alarms. When testing a series of interconnected units, each unit must be tested individually. Make sure all units alarm when tested.

INTERCONNECTED UNITS

AC/DC Alarms can be interconnected. Under AC power, all units will Alarm when one senses smoke or CO. When power is interrupted, the units in the series will continue to send and receive signals. Interconnected units can provide earlier warning of fire than stand-alone units, especially if a fire starts in a remote area of the dwelling. If any unit in the series senses smoke, all units will Alarm.

To determine which Alarm initiated an Alarm, see table:

During an Alarm	On Initiating Alarm(s): Red LED(s) flashes (flash) rapidly On All Other Alarms: Red LED is Off
-----------------	---

DANGER!

If any unit in the series does not Alarm, TURN OFF POWER and recheck connections. If it does not Alarm when you restore power, replace it immediately.

! WARNING!

Failure to meet any of the above requirements could damage the units and cause them to malfunction, removing your protection.

COMPATIBLE INTERCONNECTED UNITS

IMPORTANT!

Interconnect units within a single family residence only. Otherwise all households will experience unwanted alarms when you test any unit in the series. Interconnected units will only work if they are wired to compatible units and all requirements are met. This unit is designed to be compatible with: First Alert® Smoke Alarm Models: 9120BA, 9120LBLA, 7010BA, 3120BA, SA520A, and 7020BSLA; Smoke/CO Models: SC9120BA, SC9120LBLA, SC7010BA and 7030BSLA; BRK Electronics® CO Alarm Models CO5120BNA, Heat Alarms: HD6135FBA, and Google Nest Protect, RM4, SLED177.

INTERCONNECTED UNITS MUST MEET ALL OF THE FOLLOWING REQUIREMENTS:

- A maximum of 18 compatible units may be interconnected (Maximum of 12 smoke alarms).
- The same fuse or circuit breaker must power all interconnected units.
- The total length of wire interconnecting the units should be less than 1000 feet (300 meters). This type of wire is commonly available at Hardware and Electrical Supply stores.
- All wiring must conform to all local electrical codes and NFPA 70 (NEC). Refer to NFPA 72, NFPA 101, and/or your local building code for further connection requirements

Wireless Frequency: This alarm supports wireless frequency of 2.4Ghz and 5Ghz. For best results, recommended to use with a 802.11 b/g/n/ac router.

TESTING & MAINTENANCE

WEEKLY TESTING

! WARNING!

- NEVER use an open flame of any kind to test this unit. You might accidentally damage or set fire to the unit or to your home. NEVER use vehicle exhaust! Exhaust may cause permanent damage and voids your warranty.
- If the Alarm ever fails to test properly, replace it immediately. Products under warranty may be returned to the manufacturer for replacement.

! CAUTION!

It is important to test this unit every week to make sure it is working properly. Using the test button is the recommended way to test this Smoke/CO Alarm.

You can test this Smoke/CO Alarm by pressing and releasing the Test/Silence button on the Alarm cover.

Activate the Alarm test, reset or silence function by use of a finger or thumb. Use of any other instrument is strictly prohibited.

During testing, you will see and hear the following sequence:

- The Alarm Voice announces “This is only a test. The alarm will sound. The alarm is loud. The test will start in 5 seconds. Press to cancel. 5 4 3 2 1” “Testing Smoke” The Horn will sound 3 beeps, and red halo flashes – pause – 3 beeps and red halo flashes.
- Next the Alarm Voice will say “Testing Carbon Monoxide” Horn will sound 4 beeps and red halo flashes – pause – 4 beeps and red halo flashes. The Alarm Voice announces “The highest level of CO was XXX ppm ” “Attempting interconnect test, this may take a minute”. Red Pulse for 24 seconds, tone and then say “Test Complete” “Everything looks good”.
- Hardwired interconnected alarms will sound their horns during the smoke and CO test. If the unit does not alarm, make sure the battery pack and wired connections are correctly installed, and test again. If the unit still does not alarm, replace it immediately.

“SMART INTERCONNECT” FEATURE

This Alarm includes “Smart Interconnect” which enables the Alarm to be interconnected with other First Alert® and BRK Smoke, Combination and “Smart Interconnect” CO Alarms. When smoke is detected, all Alarms will sound the smoke horn pattern. When CO is detected, “Smart Interconnect” Alarms will sound the CO horn pattern. Alarms that do not have the “Smart Interconnect” feature will remain silent during a CO Alarm.

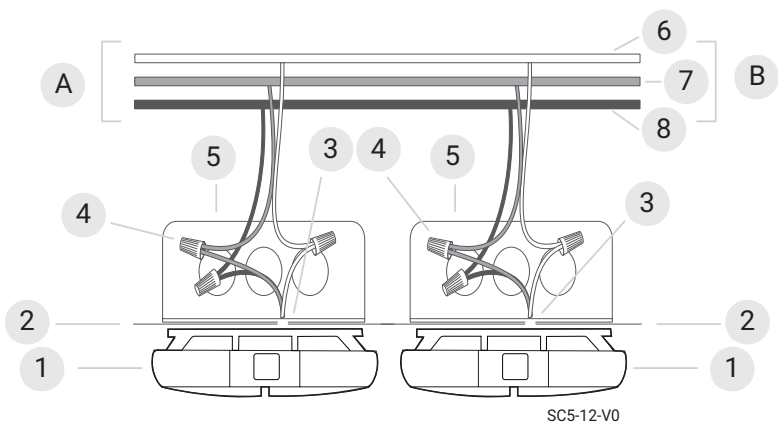

A	Unswitched 120VAC 60 Hz Source	B	To additional units; Maximum = 18 total (Maximum 12 Smoke Alarms)
1	Alarm	5	Junction Box
2	Ceiling or Wall	6	Neutral Wire (White)
3	Power Connector	7	Interconnect Wire (Orange)
4	Wire Nut	8	Hot Wire (Black)

TESTING & MAINTENANCE CONTINUED

REGULAR MAINTENANCE

- This unit has been designed to be as maintenance-free as possible, but there are a few simple things you must do to keep it working properly:
- Test it at least once a week.
- Clean the Smoke/CO Alarm at least once a month; gently vacuum the outside of the Smoke/CO Alarm using your household vacuum’s soft brush attachment. Test the Smoke/CO Alarm. Never use water, cleaners or solvents since they may damage the unit.
- If the Smoke/CO Alarm becomes contaminated by excessive dirt, dust and/or grime, and cannot be cleaned to avoid unwanted alarms, replace the unit immediately.
- If the green power LED flashes 2 times every minute (horn is silent) it means that the Alarm needs to be cleaned as indicated above. If green light continues to flash, replace Alarm.
- Relocate the unit if it sounds frequent unwanted alarms. See “Where This Alarm Should Not Be Installed” for details.
- When the battery becomes weak, the voice announcement will announce every minute for 5 minutes, then the Alarm will “chirp” (the low battery warning), and the Voice will say “Replace battery in [Location, example “Basement”].” This warning should last 7 days, but you should replace the battery pack immediately to continue your protection. The Halo LED will flash On for 0.2 seconds/Off every minute.
- Protect or cover the alarm when doing any maintenance to home i.e. sanding floors, painting, drywall patching, etc. to prevent contamination.

RESPONDING TO AN ALARM

! WARNING!

- If the unit alarms and you are not testing the unit, it is warning you of a potentially dangerous situation that requires your immediate attention. NEVER ignore any alarm. Ignoring the alarm may result in injury or death.
- Never remove the batteries from a battery operated Smoke/CO Alarm to stop an unwanted alarm (caused by cooking smoke, etc.). Removing batteries disables the alarm so it cannot sense smoke, and removes your protection. Instead open a window or fan the smoke away from the unit. The alarm will reset automatically.
- If the unit alarms get everyone out of the house immediately.
- Alarms have various limitations. See “General Limitations of Smoke/CO Alarms” for details.
- ACTUATION OF YOUR CO ALARM INDICATES THE PRESENCE OF CARBON MONOXIDE (CO) WHICH CAN KILL YOU. IN OTHER WORDS, WHEN YOUR CO ALARM SOUNDS, YOU MUST NOT IGNORE IT!

WHAT TO DO FIRST: IDENTIFY THE TYPE OF ALARM SIGNAL

IF THE CO ALARM SIGNAL SOUNDS:

“ALARM-MOVE TO FRESH AIR”

IF THE ALARM HORN SOUNDS 4 BEEPS, PAUSE, 4 BEEPS, PAUSE MOVE EVERYONE TO A SOURCE OF FRESH AIR. NOTE: THIS INITIATING CO DETECTOR’S HALO LED WILL ALSO FLASH RED.

- Press and release the Test/Silence button.
- CALL YOUR EMERGENCY SERVICES, FIRE DEPARTMENT OR 911. WRITE DOWN THE NUMBER OF YOUR LOCAL EMERGENCY SERVICE HERE: _____
- IMMEDIATELY MOVE TO FRESH AIR—OUTDOORS OR BY AN OPEN DOOR OR WINDOW. DO A HEAD COUNT TO CHECK THAT ALL PERSONS ARE ACCOUNTED FOR. DO NOT RE-ENTER THE PREMISES, OR MOVE AWAY FROM THE OPEN DOOR OR WINDOW UNTIL THE EMERGENCY SERVICES RESPONDER HAS ARRIVED, THE PREMISES HAVE BEEN AIRED OUT, AND YOUR CO ALARM REMAINS IN ITS NORMAL CONDITION.
- After following steps 1-3, if your CO Alarm reactivates within a 24-hour period, repeat steps 1-3 and call a qualified appliance technician to investigate for sources of CO from fuel-burning equipment and appliances, and inspect for proper operation of this equipment. If problems are identified during this inspection have the equipment serviced immediately. Note any combustion equipment not inspected by the technician, and consult the manufacturers’ instructions, or contact the manufacturers directly, for more information about CO safety and this equipment. Make sure that motor vehicles are not, and have not, been operating in an attached garage or adjacent to the residence. Write down the number of a qualified appliance technician here: _____

NOTE: A qualified appliance technician is defined as “a person, firm, corporation, or company that either in person or through a representative, is engaged in and responsible for the installation, testing, servicing, or replacement of heating, ventilation, air conditioning (HVAC) equipment, combustion appliances and equipment, and/or gas fireplaces or other decorative combustion equipment.”

SILENCES THE LOW BATTERY WARNING

This Silence Feature can temporarily quiet the low battery warning “chirp” for up to 8 hours. Press and release the Test/Silence button on the Alarm cover until you hear the acknowledge “chirp”. When low battery is silenced, the unit will return to normal operation for 8 hours. Low battery silence cannot be deactivated.

Once the low battery warning “chirp” Silence Feature is activated, the unit continues to flash the green light once a minute for 8 hours. After 8 hours, the low battery “chirp” will resume. The Alarm will continue to operate as long as AC power is supplied. However, replace the batteries as soon as possible, to maintain protection in event of a power outage.

To silence alarms in an interconnected series: To silence an interconnected series of Smoke/CO Alarms, you must press the Test/Silence button on the initiating alarm (The unit with the flashing red light; the red light will be off on all other Alarms.). If you press the Test/Silence on any other Alarm, it will only silence that unit, not the whole interconnected series.

SILENCING THE END OF LIFE SIGNAL

This Silence Feature can temporarily quiet the End of Life warning “chirps” for 2 days. You can silence the End of Life warning “chirps” by pressing the Test/Silence button. The horn will chirp, acknowledging that the End-of-Life Silence Feature has been activated. After approximately 2 days, the End-of-Life “chirp” will resume. The alarm end-of-life chirp can not be silenced after 14 days following the initial end-of-life signal.

The Alarm will also provide an audible End-of-Life Signal approximately 10 years after installation to remind you to replace the unit. Optionally, an EOL Heads-Up can be enabled which will notify the customer 2 weeks prior to EOL. The Heads-Up silence will last 2 weeks or until EOL begins. Also when EOL is silenced, the green power led will continue to blink 5 times per minute.

RESPONDING TO AN ALARM (CONTINUED)

WHAT TO DO IN CASE OF FIRE

- Don’t panic; stay calm. Follow your family escape plan.
- Get out of the house as quickly as possible. Don’t stop to get dressed or collect anything.
- Feel doors with the back of your hand before opening them. If a door is cool, open it slowly.
- Don’t open a hot door. Keep doors and windows closed, unless you must escape through them.
- Cover your nose and mouth with a cloth (preferably damp). Take short, shallow breaths.
- Meet at your planned meeting place outside your home.
- Do a head count to make sure everybody got out safely.
- Call the Fire Department as soon as possible from outside. Give your address, and name.
- Never go back inside a burning building for any reason.
- Contact your Fire Department for ideas on making your home safer.

USING THE SILENCE FEATURES

! WARNING!

- The Silence Feature is intended to temporarily silence the horn while you identify and correct the problem. Do not use the Silence Feature in emergency situations. It will not correct a CO problem or extinguish a fire.
- The Silence Feature can temporarily quiet an unwanted alarm for several minutes. You can silence this Smoke/CO Alarm by pressing and releasing the Test/Silence button on the alarm cover.
- After the Test/Silence button is released, the Alarm Voice will say “Horn silenced, detector active.” The Red LED blinks during the silence mode.

When the Smoke Alarm is Silenced	When the CO is Silenced
The Smoke Alarm will remain silent for up to 10 minutes, then return to normal operation.	The CO Alarm will remain silent for up to 6 minutes.
If the smoke has not cleared—or continues to increase—the device will go back into alarm.	After 6 minutes, if CO levels remain potentially dangerous the horn will start sounding again.

AFTER AN ALARM

After the emergency responders arrive, the premises aired out, and your CO Alarm remains in its normal condition, you can check what the highest carbon monoxide level sensed was by initiating a self test. The highest level of CO is announced during the test. The maximum level will automatically reset after the message is played.

Action	What You Will See & Hear
Normal Operations	Voice: Silent; Power LED: Constant Green; Horn: Silent
When You Test the Alarm	Voice: “This is only a test. The alarm will sound. The alarm is loud. The test will start in 5 seconds. Press to cancel. 5 4 3 2 1” “Testing Smoke”; The Horn will sound 3 beeps, and red halo flashes – pause – 3 beeps and red halo flashes; Next the Alarm Voice will say “Testing Carbon Monoxide” Horn will sound 4 beeps and red halo flashes – pause – 4 beeps and red halo flashes. The Alarm Voice will say “The highest level of Co was XXX ppm ” “Attempting interconnect test, this may take a minute”. Red Swell for 24 seconds, tone and then say “Test Complete” “Everything looks good”; Power LED: Off
If Battery Becomes Low	Voice: “Replace battery in [Location, example “Basement”] now.” If AC power is removed, the voice announcement will end after 5 minutes, but the chirp and amber flash will continue ; Horn: chirps once a minute; Halo LED: 1 amber flash every minute. In the event of a power outage lasting longer than 5 minutes, the voice message will no longer play, but the other signals will continue.
If Alarm is Not Operating Properly (MALFUNCTION SIGNAL)	Voice: “Detector error in [Location, example “Basement”], please see manual.”; Horn: 3 chirps every minute; Halo LED: Flashes 2 amber flashes once a minute.
Alarm has reached its End of Life	Voice: “Alarm has reached the end of its life. Replace the alarm in the <location>. Replace now.” Horn: 5 chirps. Power LED: 5 flashes. Halo LED: 1 amber flash. The signals are repeated every minute.
Smoke is Detected	Horn: 3 beeps, pause, red Halo LED flashes red in sync with the horn; Voice (repeated every 4 seconds): The first voice announcement says “Emergency” and second “Smoke Detected”. If the customer has specified a location the next will be “in the <room>”, if the alarm may be silenced, “Press to Silence”. NOTE: If using the app to remotely silence the device, the user must check for smoke/fire at the initiating alarm.
Smoke Alarm is Silenced	Voice: “The Smoke Alarm is Silenced”; Halo LED: Off; Power LED: Flashes Red
Alarm Levels of CO are Detected	Horn: 4 fast beeps, pause, 4 fast beeps, pause”; Halo LED: Flashes red in sync with the horn. Voice (repeated every 5.7 seconds): The first voice announcement says “Emergency” and second “Carbon Monoxide Detected”. If the customer has specified a location the next will be “in the <room>”, if the alarm may be silenced, “Press to Silence”. *NOTE: In the event of a power outage lasting longer than 5 minutes, the signal will repeat every minute.
CO Alarm is Silenced	Voice: “The Carbon Monoxide Alarm is Silenced”; Horn: Off; Halo LED: Red flashes in the same pattern as an active alarm.